

THIS DRAWING IS UNPUBLISHED. RELEASED FOR PUBLICATION
 © COPYRIGHT BY TYCO ELECTRONICS CORPORATION. ALL RIGHTS RESERVED.

LOC	DIST	REVISIONS					
GP	00	P	LTR	DESCRIPTION	DATE	DWN	APVD
			A1	REV PER ECR-15-007399	13MAY2015	ML	SZ

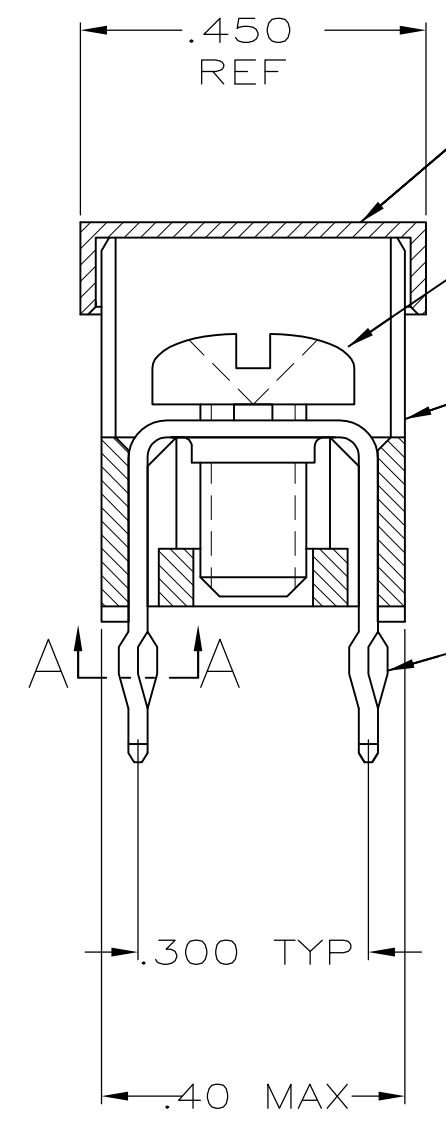
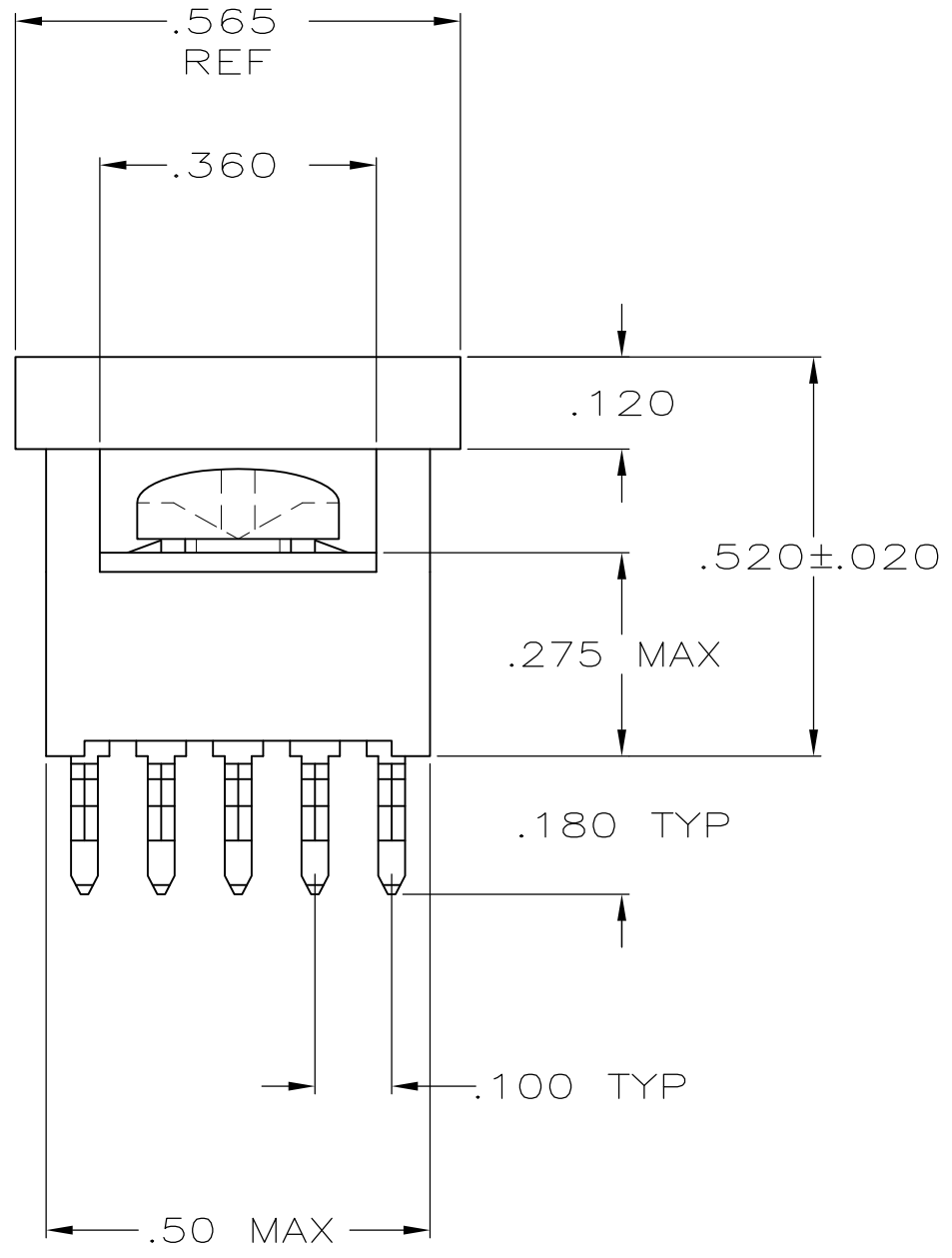

COVER
 SCREW, 993879-1
 SUPPLIED UNASSEMBLED, SEE TABLE
 HOUSING
 TAP

- 1 TO PREVENT THREAD STRIPPING, SCREW TORQUE SHOULD NOT EXCEED 9 IN LBS.
- 2 TAP HOLE IS 6-32UNC-2B, TWO MIN THREADS.
- 3 PACKAGED BULK.
- 4 HOUSING: NYLON.
TAP: COPPER ALLOY 725, .025 THICK
- 5 TAP: .000150 MATTE TIN OVER .000050 NICKEL

6. REFERENCE APPLICATION SPECIFICATION 114-11000 FOR DRILL HOLE SIZES AND FINISHES.



SECTION A-A
 SCALE 10:1
 10 PLACES

3	YES	YES	5055557-4
3	YES	NO	5055557-3
PACKAGING	HOUSING AND TAP ASSEMBLED	SCREW	PART NO.

THIS DRAWING IS A CONTROLLED DOCUMENT.		DWN J. ALCORTA - 05-04-05 DOCK5	tyco Tyco Electronics Corporation	
DIMENSIONS: INCHES		CHK A. FRANTUM 05-04-05	Electronics Harrisburg, PA 17105-3608	
TOLERANCES UNLESS OTHERWISE SPECIFIED:		APVD S. FLICKINGER 05-04-05	NAME	
0 PLC ± -	1 PLC ± -	PRODUCT SPEC	TAP ASSEMBLY, POWER DISTRIBUTION	
2 PLC ± -	3 PLC ± .010	108-11030		
4 PLC ± -	ANGLES ± -	APPLICATION SPEC		
MATERIAL 4	FINISH 5	114-11000	SIZE	CAGE CODE
		WEIGHT -	A3	00779
CUSTOMER DRAWING			DRAWING NO	RESTRICTED TO
			C-5055557	-
			SCALE 4:1	SHEET 1 OF 1
			REV	A1